

VICINITY MAP

NTS

CERTIFICATION BY THE COUNTY CLERK

STATE OF TEXAS I
COUNTY OF BRAZOS I
I, Frank Boush, County Clerk in and for said County, do hereby certify that this plat together with its certificate of authentication was filed for record in my office the 11 day of December, 1978, in the Deed Records of Brazos County, Texas in Volume 413, Page 735.

Frank Boush
County Clerk, Brazos County, Texas
OWNERS' ACKNOWLEDGMENT AND DEDICATION

WE, THE TEXAS PRIVATE SCHOOL FOUNDATION, INC., KARL MARTIN, and wife, MARY MARTIN, and EMMA SIEVERS, Owners of the land shown on this plat and designated hereon as the VACATING AND RE-SUBDIVISION OF LOTS 1, 2, AND 3, BLOCK 4, REYNOLDS ADDITION, hereby declare LOTS 1, 2, AND 3, BLOCK 4, to be vacated and that the area be resubdivided as LOTS A, B, AND C, BLOCK 4, REYNOLDS ADDITION.

THE TEXAS PRIVATE SCHOOL FOUNDATION, INC.

BY Wesley Anderson
WESLEY ANDERSON, PRESIDENT

Carl Martin
CARL MARTIN

Mary Martin
MARY MARTIN

Emma Sievers
EMMA SIEVERS

THE STATE OF TEXAS I
COUNTY OF BRAZOS I

BEFORE ME, the undersigned authority, on this day personally appeared WESLEY ANDERSON, known to me to be the person and officer whose name is subscribed to the foregoing instrument and acknowledged to me that he executed the same as the act of said corporation and in the capacity therein stated for the purpose and consideration therein expressed.

GIVEN UNDER MY HAND AND SEAL OF OFFICE on this 10th day of December, 1978.

Brenda D. Keith
NOTARY PUBLIC IN AND FOR BRAZOS COUNTY, TEXAS

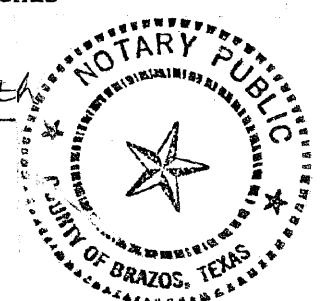

THE STATE OF TEXAS I
COUNTY OF BRAZOS I

BEFORE ME, the undersigned authority, on this day personally appeared KARL MARTIN, and wife, MARY MARTIN, known to me to be the persons whose names are subscribed to the foregoing instrument and acknowledged to me that they executed the same for the purpose and consideration therein expressed.

GIVEN UNDER MY HAND AND SEAL OF OFFICE on this 10th day of December, 1978.

Brenda D. Keith
NOTARY PUBLIC IN AND FOR BRAZOS COUNTY, TEXAS

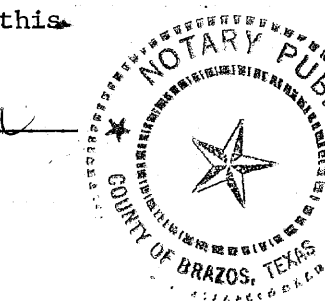

THE STATE OF TEXAS I
COUNTY OF BRAZOS I

BEFORE ME, the undersigned authority, on this day personally appeared EMMA SIEVERS, known to me to be the person whose name is subscribed to the foregoing instrument and acknowledged to me that she executed the same for the purpose and consideration therein expressed.

GIVEN UNDER MY HAND AND SEAL OF OFFICE on this 10th day of December, 1978.

Brenda D. Keith
NOTARY PUBLIC IN AND FOR BRAZOS COUNTY, TEXAS

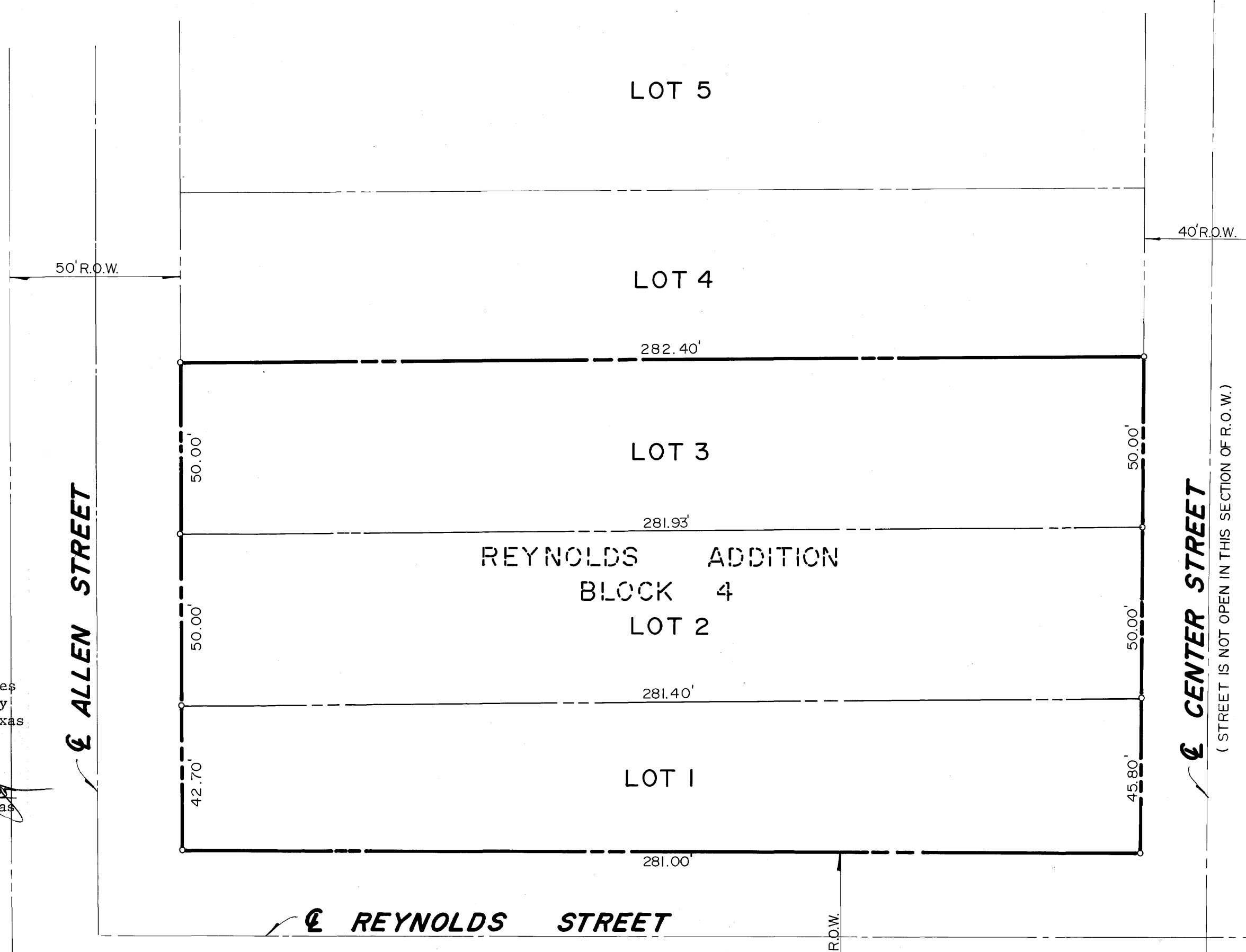
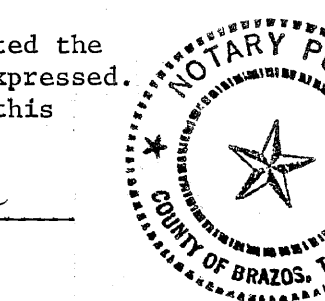

VACATING

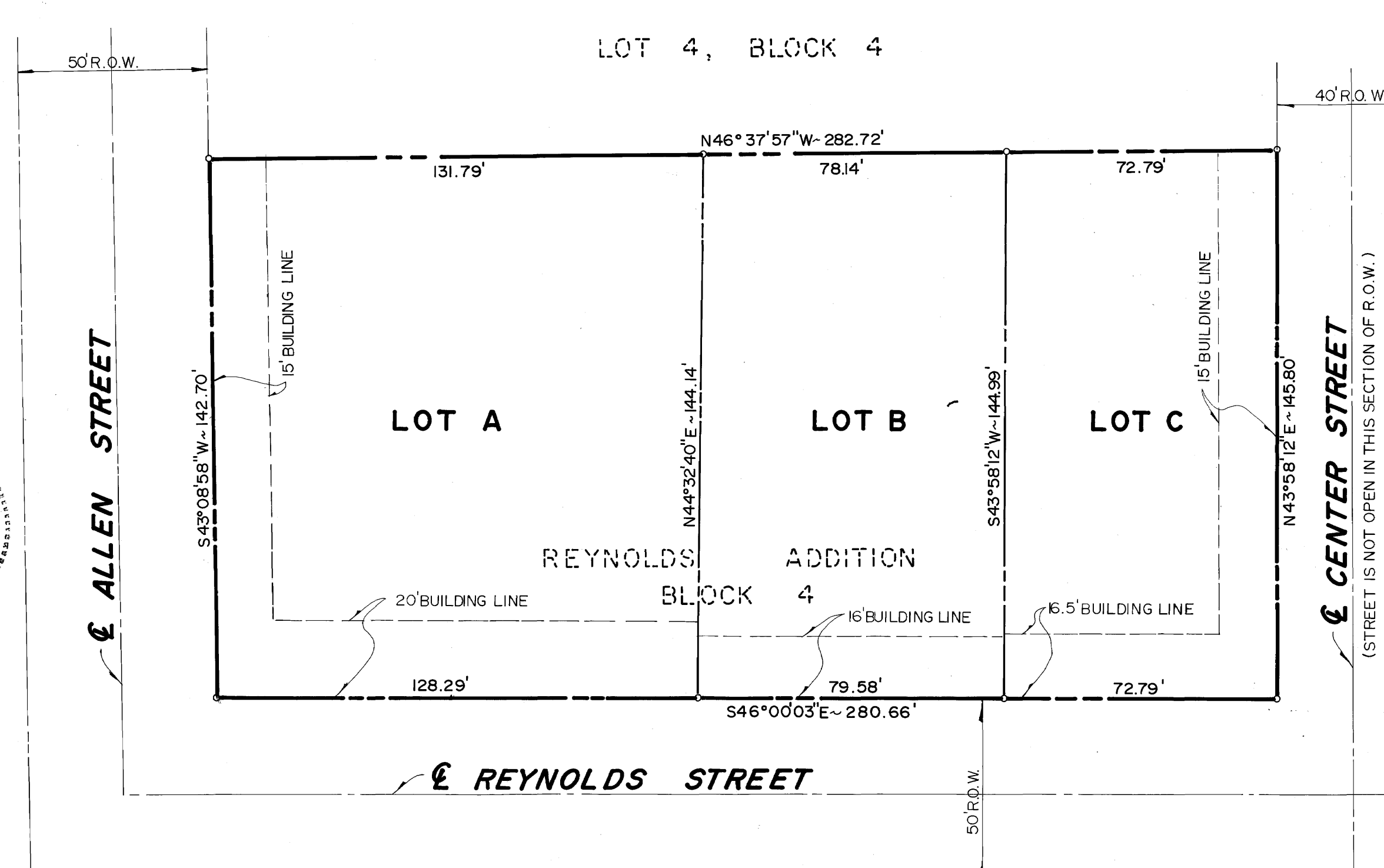

RESUBDIVISION

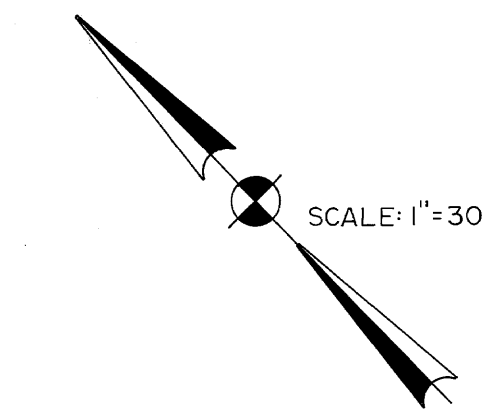

SCALE: 1"=30'

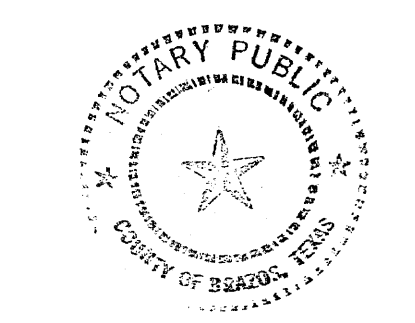
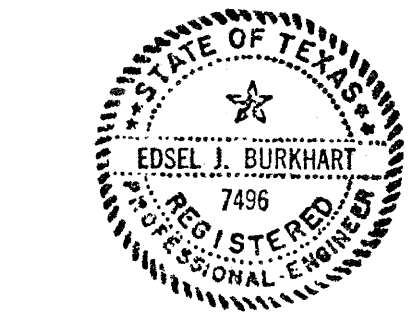
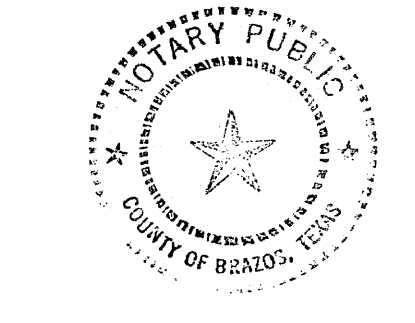
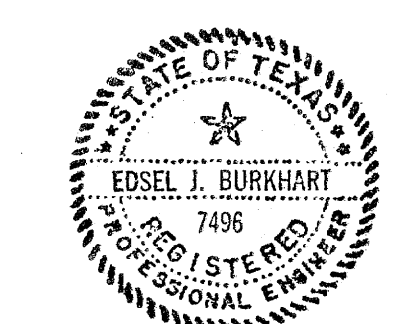

CERTIFICATION BY THE ENGINEER
I, Edsel J. Burkhardt, Registered Professional Engineer No. 7496, in the State of Texas, hereby certify that proper engineering consideration has been given this plat.
Edsel J. Burkhardt
Edsel J. Burkhardt, R.P.E. No. 7496
Subscribed and sworn to before me, the undersigned authority on this the 29th day of November, 1978.
Sue McRae
Notary Public, Brazos County, Texas

CERTIFICATE BY THE SURVEYOR
I, EDSSEL J. BURKHART, Registered Professional Engineer No. 7496 in the State of Texas, hereby certify that this plat is true and correct and was prepared from a survey made on the ground under my supervision.
Edsel J. Burkhardt
EDSEL J. BURKHART, R.P.E. NO. 7496
SUBSCRIBED AND SWORN TO before me, the undersigned authority, on this the 29th day of November, 1978.
Sue McRae
NOTARY PUBLIC IN AND FOR BRAZOS COUNTY, TEXAS

CERTIFICATE BY THE CITY PLANNER
I, the undersigned, City Planner of the City of Bryan hereby certify that this subdivision plat conforms to all requirements of the subdivision regulations of the City of Bryan, Texas.
Frank C. Ziskie
City Planner, City of Bryan, Texas

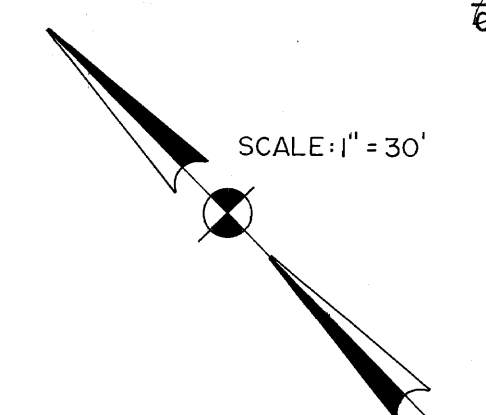

SCALE: 1"=30'

APPROVAL OF THE PLANNING COMMISSION
I, D.D. Williamson, Chairman of the City Planning Commission of the City of Bryan, State of Texas, hereby certify that the attached plat was duly filed for approval with the City Planning Commission of the City of Bryan on the 27 day of December, 1978, and same was duly approved on the 7 day of December, 1978 by said Commission.
D.D. Williamson
Chairman, City Planning Commission, Bryan, Texas

FINAL PLAT
VACATING and RESUBDIVISION
OF LOTS 1, 2 and 3, BLOCK 4
REYNOLDS ADDITION
VOLUME 38, PAGE 269
JOHN AUSTIN LEAGUE A-8
BRYAN, BRAZOS COUNTY, TEXAS
OWNED and DEVELOPED by:
THE TEXAS PRIVATE SCHOOL FOUNDATION, INC.
WESLEY ANDERSON, PRESIDENT
PREPARED BY:
SPENCER J. BUCHANAN & ASSOCIATES, INC.
CONSULTING ENGINEERS BRYAN, TEXAS
SCALE: 1"=30'
NOVEMBER, 1978

FILED
DEC 11 1978
FRANK C. ZISKIE
County Clerk, Brazos County, Texas

155006

NOTE: There is a minimum five foot setback line on all side and back lot lines.

on base 2/10/78